

		410	500
Table			
Table Diameter	mm	Ø410	Ø500
T-Slot	mm	14H7	14H7
Max. Table Loading Capacity	kgs	H: 200 / T: 150	H: 300 / T: 250
Travel			
X Axis Travel	mm	560	560
Y Axis Travel	mm	500	480
Z Axis Travel	mm	450	450
A Axis Tilting Angle Range	deg.	+30°~120°	+30°~120°
C Axis Rotary Angle	deg.	360°	360°
Spindle Nose to Table Surface	mm	150~600	150~600
Spindle			
Spindle Taper		ISO-40 (CAT,DIN,HSK-63A)	
Spindle Speed	rpm	8000(10000, 12000, 15000)	
Transmission Method		Belt (Direct)	Belt (Direct)
Spindle Motor	kW	7.5/11	7.5/11
ATC			
Magazine Capacity	tools	30(40)	30(40)
Tool Selection Method		Random	Random
Max. Diameter / W/O Adjacent	mm	Ø 71 / Ø 150	Ø 71 / Ø 150
Max. Tool Weight	mm	280	280
Max. Tool Length	kgs	7	7
Tool Change Time	sec	T-T 4.5	T-T 4.5
3 Axis Traverse			
3 Axis Cutting Feedrate	m/min	12	12
3 Axis Rapid Traverse	m/min	36/36/36 (48/48/48)	36/36/36 (48/48/48)
A/C Axis Speed	min ⁻¹	16.6 / 11.1	16.6 / 11.1
Accuracy			
Positioning	mm	0.008	0.008
Repeatability	mm	±0.005	±0.005
Coolant			
Coolant tank Capacity	ℓ	240	240
Coolant Flow	ℓ /min	200	200
General			
Air Pressure Requirement	Kg/cm ²	5~7	5~7
Power Requirement	kva	25	25
Machine Size	mm	4330x2165x2840	4330x2165x2840
Machine Weight	kgs	7400	7700

■ Description in () are optional accessories.

■ We reserve the right to modify the design and specification without notice in advance.

Above specifications are for reference only. Correct specifications are based on actual machine.



FOCUS SEIKI CORP

No.178, Guangqi Rd., Shengang Dist.,
Taichung City 42948, Taiwan (R.O.C.)

Tel: +886-4-25612611

Fax: +886-4-25611613

E-mail: sales@focuseiki.com.tw

www.focuseiki.com.tw

Precision & Stability

High Rigidity & Performance

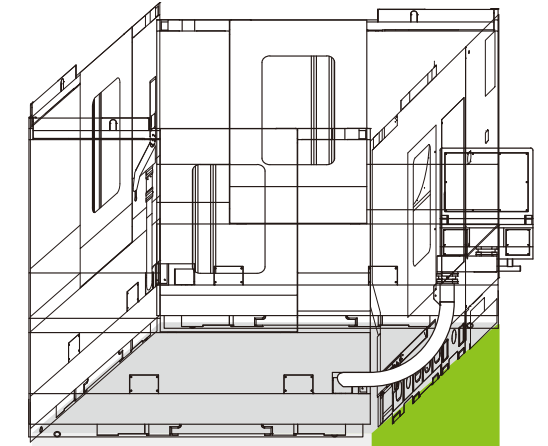

Optimum Structure Design

- Optimum design on X/Y/Z axes, best rigidity performance stabilizes axes moving and processing.
- Grounded tool magazine connected with base machine base, reduce the instability from moving column, as well as axial load.



Independent ATC connected with Base.

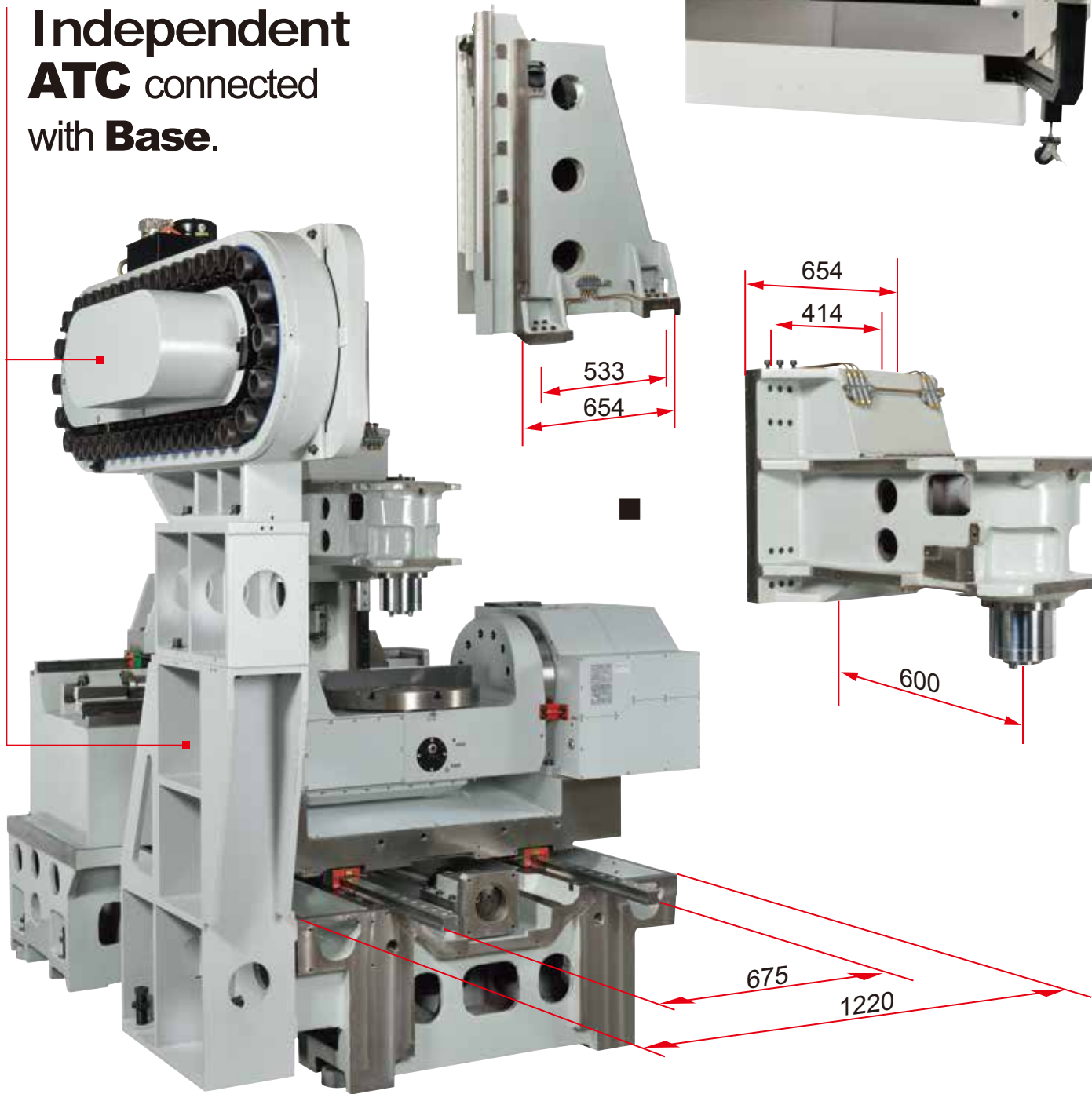

Two-stepped Column Configuration Design Reinforces the Rigidity of Cutting.

Workpiece Dimension

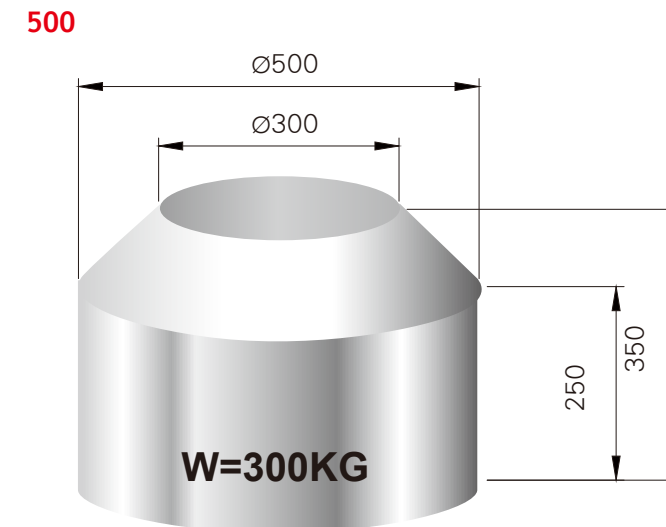
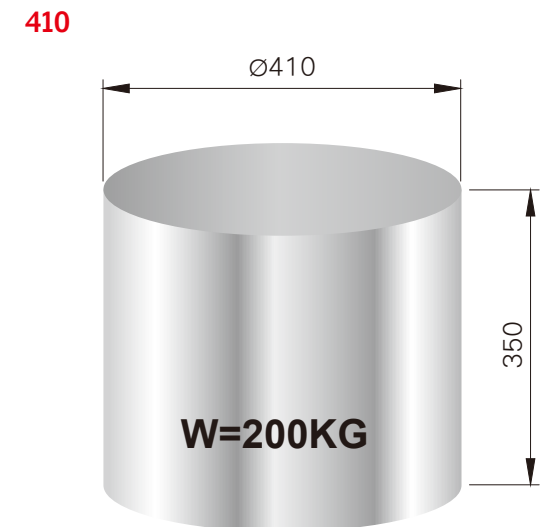

Cutting Area & Working Zone

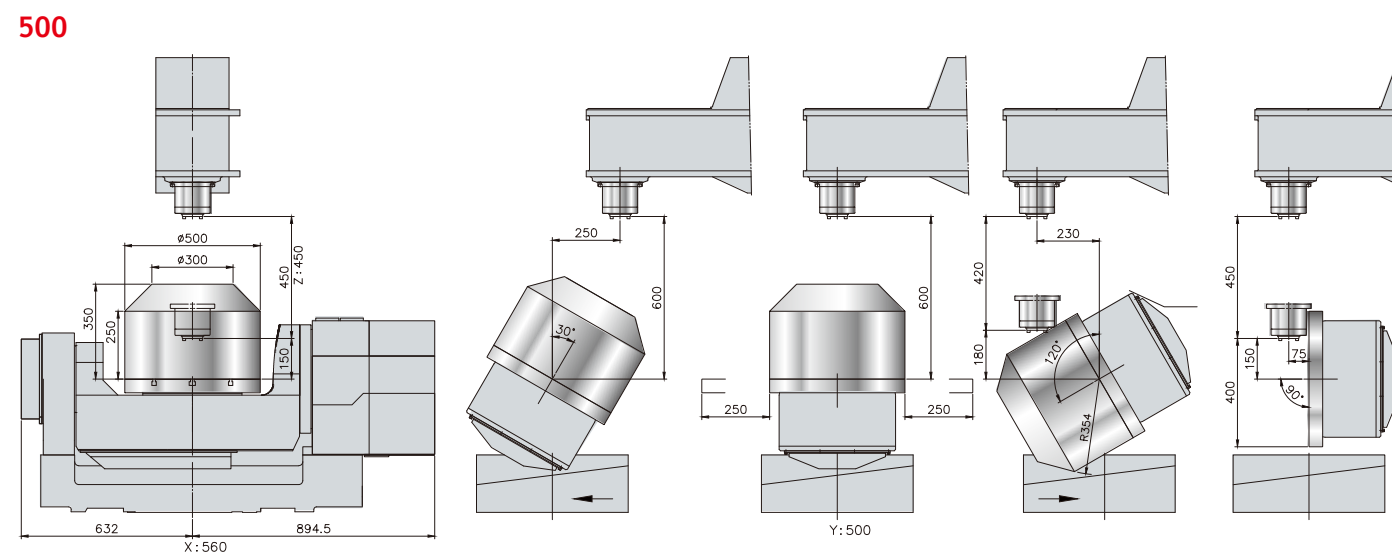
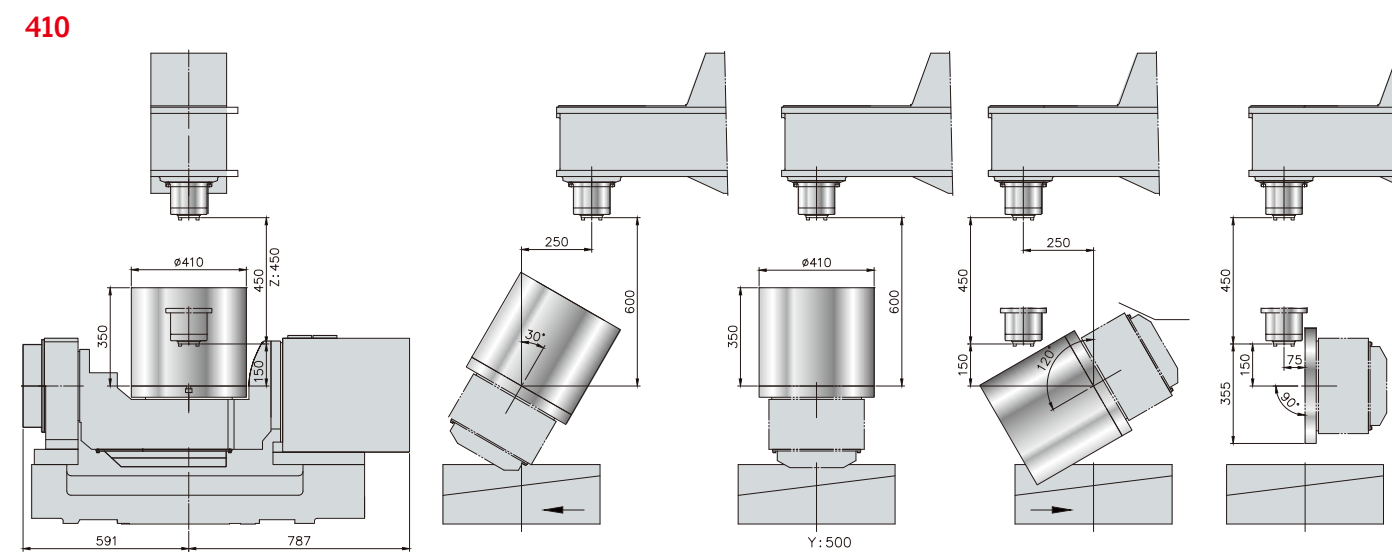

Rotary Tilting Table Specification

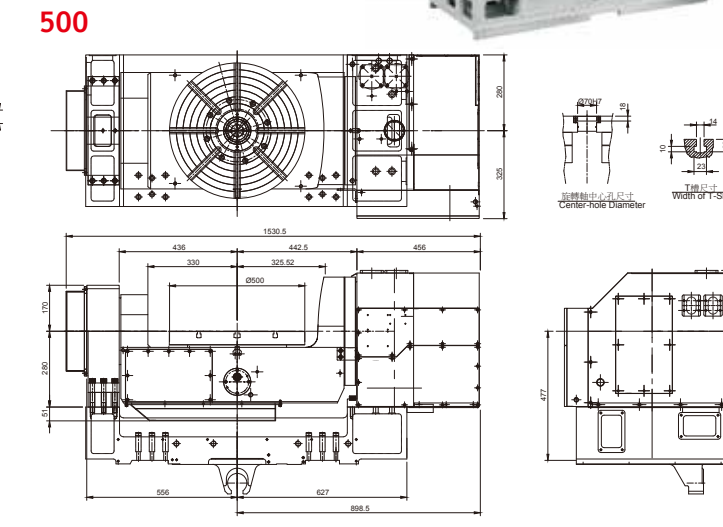
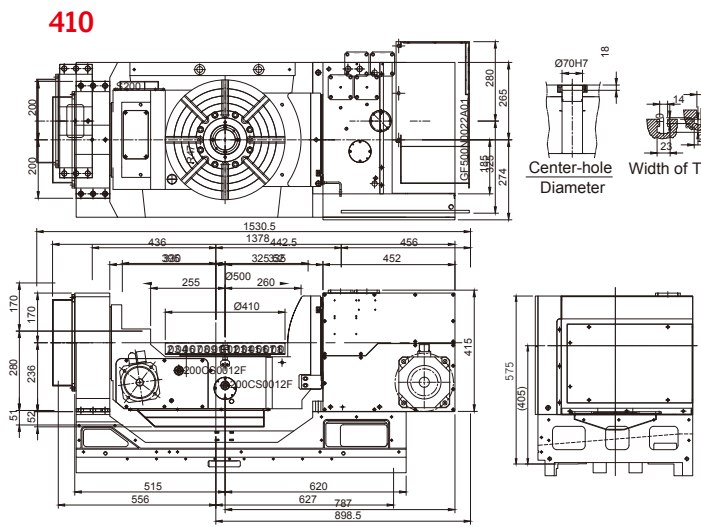

Worktable Diameter	410 mm	
Center Bore Diameter	70H7 mm	
Width of T-slot	14H7 mm	
Max. Loading Capacity	In Horizontal 200 Kg	In Tilt 150 Kg
Axis	Rotary	Tilt
Transmission Ratio	1 : 120	1 : 150
Max. Table Speed	16.6 min ⁻¹	11.1 min ⁻¹
Resolution	0.001°	
Indexing Accuracy	15"	60"
Repeatability	6"	8"
Tilting Angle Range	+30° ~ -120°	
Clamping Torque	118 Kg.m	188 Kg.m
Allowable Cutting Torque	30 Kg.m	30 Kg.m
Pneumatic Pressure	5 ~ 7 Kgf/cm ²	

Worktable Diameter	510 mm	
Center Bore Diameter	70H7 mm	
Width of T-slot	14H7 mm	
Max. Loading Capacity	In Horizontal 300 Kg	In Tilt 250 Kg
Axis	Rotary	Tilt
Transmission Ratio	1 : 144	1 : 180
Max. Table Speed	16.6 min ⁻¹	11.1 min ⁻¹
Resolution	0.001°	
Indexing Accuracy	15"	60"
Repeatability	6"	8"
Tilting Angle Range	+30° ~ -120°	
Clamping Torque	200 Kg.m	250 Kg.m
Allowable Cutting Torque	40 Kg.m	40 Kg.m
Pneumatic Pressure	5 ~ 7 Kgf/cm ²	

Standard Accessories:

- 8000rpm Belt Type Spindle
- Fully Enclosed Guard
- Arm type ATC 40 tools
- Tilting with Encoder
- Working Light & Alarm Light
- Coolant & Chip Flushing System
- Auto Power Off
- Rigid Tapping
- Leveling Screws & Blocks

Optional Accessories:

- Coolant Through Spindle (CTS)
- Transformer
- Linear Scales
- Transformer
- Auto Tool Length Measurement System
- Auto Workpiece Measurement System
- Air Conditioner
- Arm Type ATC 40 Tools

Machine Dimension

	Unit:mm					
	A	B	C	D	E	F
410	870	2165	3145	3475	4330	2390~2840
500	870	2165	3145	3475	4330	2390~2840

